

YS080L

Payload 80Kgf

Installation method		Application	
Floor	●	Spot welding	
Ceiling		Arc welding	●
Wall surface		Handling	●
		Assembly	
		Sealing	●
		Painting	

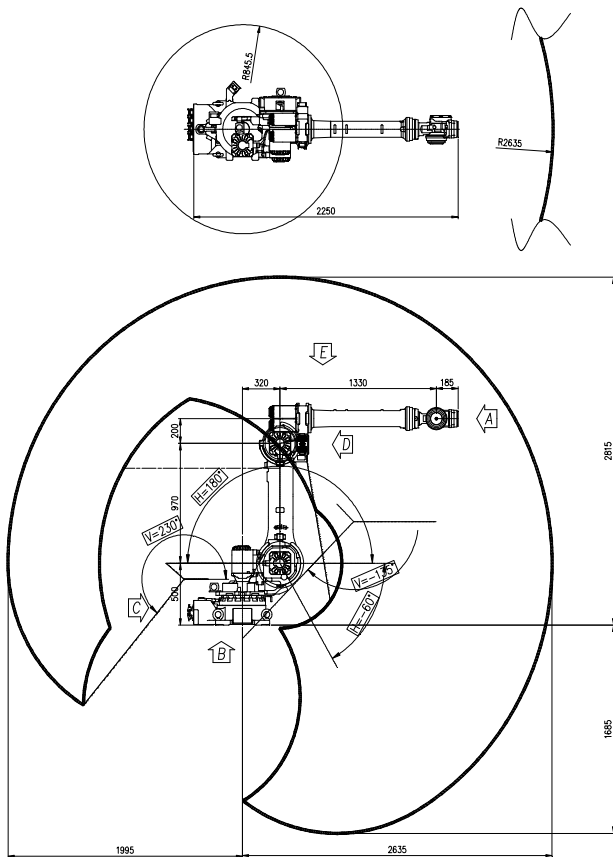

View A: Detailed drawing of the wrist attachment part

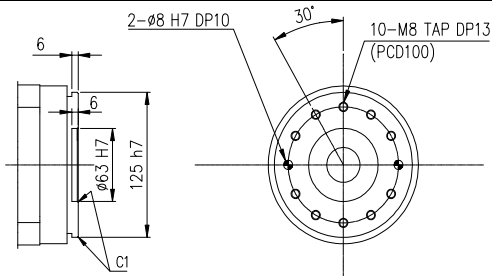

View B: Dimensional drawing for the floor installation of the body

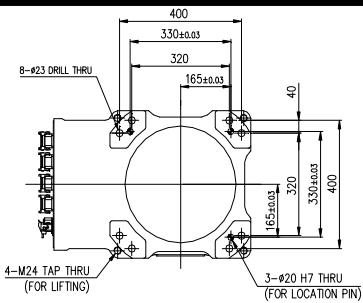

View C: Application cable connection part

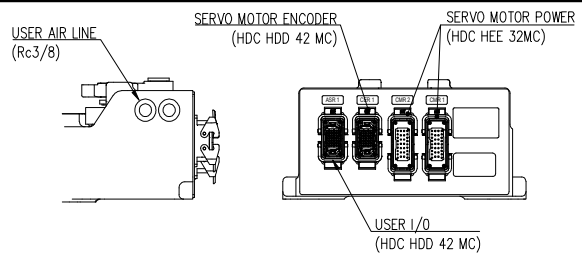

View D: Application cable connection part

Wrist-axis torque line diagram

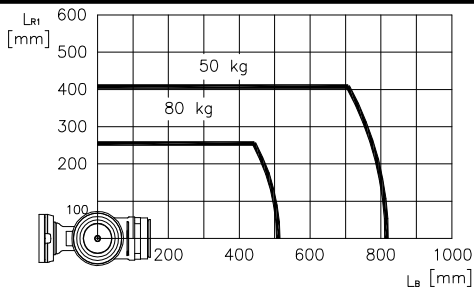

View E: Details of the application ancillary part attachment

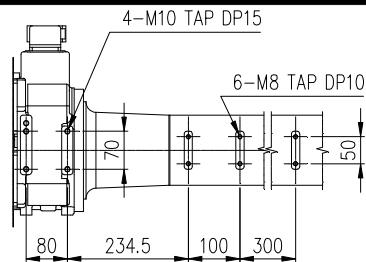

** For product improvement, some of the ratings, specifications, dimensions, etc. are subject to changes without notice.