

HS200L

Payload 200Kgf

Installation method		Application	
Floor	●	Spot welding	●
Ceiling		Arc welding	
Wall surface		Handling	●
		Assembly	
		Sealing	●
		Painting	

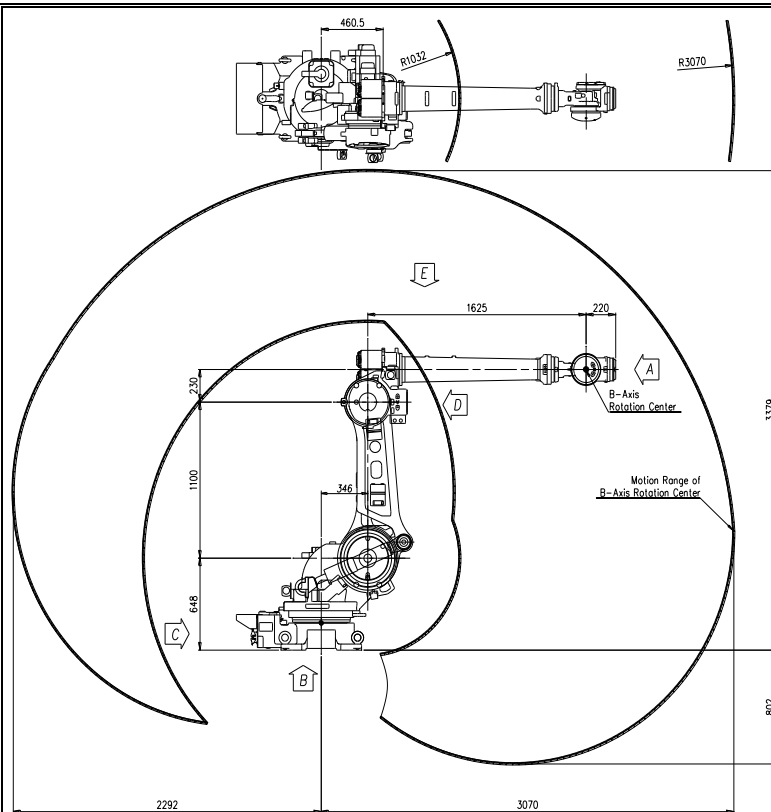

View A: Detailed drawing of the wrist attachment part

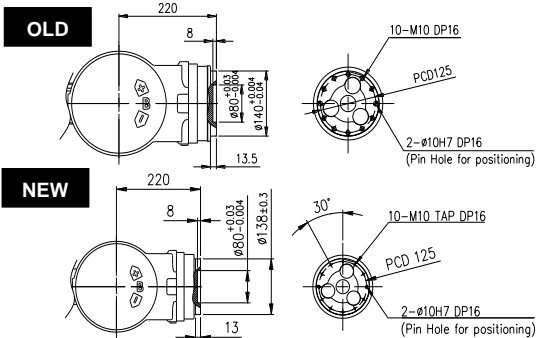

View B: Dimensional drawing for the floor installation of the body

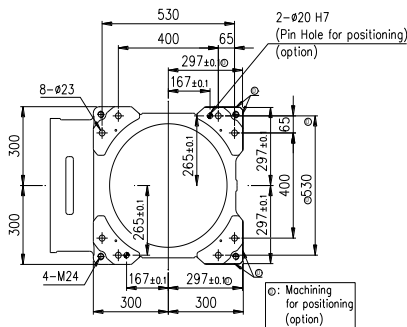

Wrist-axis torque line diagram

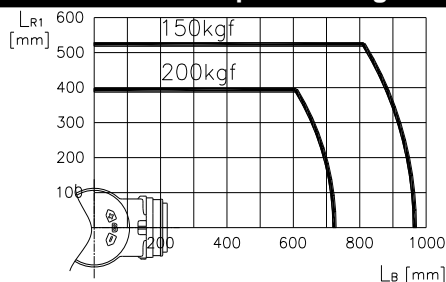

Item		Specification	
Robot model		HS200L	
Payload		200 Kg	
Structure		Articulated	
Degree of freedom		6 axes	
Max. working envelope	Arm	S Swivel	$\pm 3.142 \text{ rad } (\pm 180^\circ)$
		H Horizontal	$+2.705 \sim -0.175 \text{ rad } (+155^\circ \sim +10^\circ)$
		V Vertical	$+3.316 \sim -1.396 \text{ rad } (+190^\circ \sim -80^\circ)$
	Wrist	R2 Rotation 2	$\pm 6.284 \text{ rad } (\pm 360^\circ)$
		B Bending	$\pm 2.234 \text{ rad } (\pm 128^\circ)$
Max. working speed	Arm	S Swivel	1.658 rad / s (95° / s)
		H Horizontal	1.484 rad / s (85° / s)
		V Vertical	1.484 rad / s (85° / s)
	Wrist	R2 Rotation 2	2.094 rad / s (120° / s)
		B Bending	2.094 rad / s (120° / s)
Wrist torque	R2 Rotation 2	B Bending	1,422 Nm (145 kgfm)
		R1 Rotation 1	770 Nm (78 kgfm)
	R1 Rotation 1	B Bending	1,422 Nm (145 kgfm)
Accuracy of position repeatability		$\pm 0.06 \text{ mm}$	
Ambient Temperature		0 ~ 45 °C (273 ~ 318 K)	
Robot's Weight		1,223 Kg	

* When the optional limit switch is attached, the action range of the main axis will be limited (see the manual)

View C: Application cable connection part

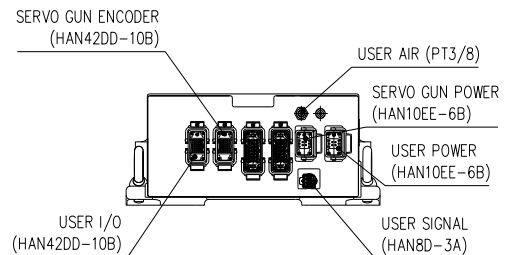

View D: Application cable connection part

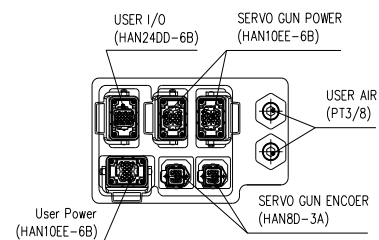

View E: Details of the application ancillary part attachment

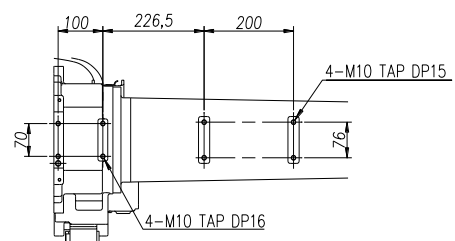

** For product improvement, some of the ratings, specifications, dimensions, etc. are subject to changes without notice.